

# Schäffer Lader

## ***THE COMPACT CLASS***

**3350 | 3360**

**4350 | 4360**



**Optimised ergonomics  
and power**

## YARD LOADERS, WHEEL LOADERS AND TELESCOPIC LOADERS ...

from 14 kW (20 HP) to 132 kW (180 HP). At SCHÄFFER Loaders, we have a proud 50 year history of creating loaders for individual requirements. Our customers have made us what we are today: one of the world's most competitive and successful suppliers of yard loaders, wheel loaders and telescopic loaders. Every day our team creates new custom solutions that combine years of experience with a spirit of innovation. Our products set industry standards for reliability and durability, which means you save with lower servicing costs over the life of your vehicle. The Schaffer name is your assurance of superior performance, safety and comfort for years to come.



## **THE SCHÄFFER COMPACT CLASS: OPTIMISED ERGONOMICS AND POWER**

The SCHÄFFER 3300/4300 compact series are the ideal equipment for use in hard to reach areas where great power and user-friendliness must be combined with compact machine dimensions, making SCHÄFFER a leading brand in this segment. The compact machines are also very sturdy and can be used even at extreme temperatures, be it minus 30 degrees Celsius in Iceland or plus 45 degrees Celsius in Australia. The reliability and power of SCHÄFFER loaders is legendary. They can be used for a wide range of tasks in fields such as agriculture, horticulture and landscape gardening, the building industry, warehousing and municipal services. With SCHÄFFER, you can simply move more in less time.

### **THE COMPACT CLASS**

**3350 | 37 kW (50 HP)    3360 | 44 kW (60 HP)**

**4350 | 37 kW (50 HP)    4360 | 44 kW (60 HP)**





## COMFORT AND SAFETY? WE HAVE IT.

All articulated pendulum joints of the compact class are fully maintenance-free. The conic clamping of the joint is new. The strength of the connection improved once again by 20%. That is why we offer you a warranty for this component of 3 years or 3000 operating hours.

## THE 3300/4300 SERIES OF SCHÄFFER: ADVANTAGES AT A GLANCE

ROPS roll bar, foldable for low passages;  
You can choose between a protection roof or cab.

Adjustable steering  
column

Newly constructed engine bonnet  
offers a better isolation of the  
sound, perfect view backwards.

Kubota: World market leader  
of compact diesel motors.  
Clean, moneysaving, powerful.

Original Schäffer axles: very strong, high pushing power due  
to best setup of axle, hydrostatic drive and motor, payload of 7 t  
per axle. 4300 machines with planetary axles and automatic  
limited slip differentials.

Operators platform  
with less vibrations.



## GREAT POWERS AT WORK ...

KUBOTA is the world's leading manufacturer of compact diesel engines. The engines built into the latest generation of SCHÄFFER loaders consume even less fuel, and their fume and soot emissions were also reduced. Noise is also not an issue, as the modern GRP bonnet does not only look great but effectively reduces the noise of the engine. Mechanics and drivers will be pleased to know that they can now replace the oil filter without having to strain their fingers.

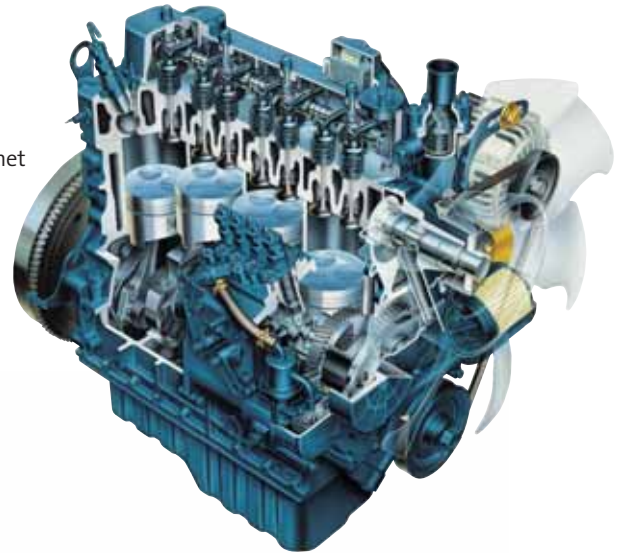

Ball bearing joints for long lifetime expectancy.

One strong lifting cylinder: narrow front chassis, perfect view forward, no tension.

Very strong faceplate: fast and safe coupling of tools  
Hydraulic quickhitch as an option.

Versatile due to big range of tools and optional equipment.

Maintenance free articulated pendulum joint with extended warranty.

CAD optimized lifting arm, best lifting height and reach, perfect parallel lift.

## 3300 AND 4300 SERIES OF SCHÄFFER: QUALITY ALL THROUGH

The modern design of the new loaders underlines Schäffer's claim to build extremely dynamic and ergonomic machines. The low engine bonnet doesn't restrict the view backwards. Due to the reduced revs of the diesel engine, a bigger hydrostat can be applied. This transforms the force of the motor into much higher pushing forces via the original Schäffer axles. The fast gear changeable hydraulically under load until 20 km/h is standard for all loaders of the series. The extended wheelbase improves the tipping loads.



The optional protection roof shelters the operator from falling objects.

# Schäffer Lader



The solid and yet compact loading arm with ball bearing joints gives lifetime expectancy.



## SCHÄFFER AXLES – FOR GREATER SAFETY AND STABILITY

SCHÄFFER axles are optimised for each model. The force of the hydrostatic drive system is converted into high pushing forces. The loader is equipped with a wear-resistant “Easy Brake” multi-disc brake. This technology is normally only used in much bigger wheel loaders.



The ROPS roll bar can be folded within a few seconds.

## TECHNICAL DATA

	3350	3360	4350	4360
<b>Motor</b>	4 Cyl. Kubota 37 kW (50 HP)	4 Cyl. Kubota Turbo 44 kW (60 HP)	4 Cyl. Kubota 37 kW (50 HP)	4 Cyl. Kubota Turbo 44 kW (60 HP)
<b>Drive Hydraulics</b>	Hydrostatic automotive	Hydrostatic automotive	Hydrostatic automotive	Hydrostatic automotive
<b>Tires</b>	10.075 - 15.3 AS Option I 11.5/80 - 15.3 AS Option II 31 x 15.5 - 15 Option III 15.0/55 - 17 Option IV 425/55 R17	10.075 - 15.3 AS Option I 11.5/80 - 15.3 AS Option II 31 x 15.5 - 15 Option III 15.0/55 - 17 Option IV 425/55 R17	11.5/80 - 15.3 AS Option I 15.0/55 - 17 Option II 425/55 R17	11.5/80 - 15.3 AS Option I 15.0/55 - 17 Option II 425/55 R17
<b>Operating Brake System</b>	Combination Hydrostatic and multiple-disk	Combination Hydrostatic and multiple-disk	Combination Hydrostatic and multiple-disk	Combination Hydrostatic and multiple-disk
<b>Parking Brake</b>	Multiple Disk in Oil Bath	Multiple Disk in Oil Bath	Multiple Disk in Oil Bath	Multiple Disk in Oil Bath
<b>Operation Hydraulics</b>	Flow Rate: 48 l/min	Flow Rate: 48 l/min	Flow Rate: 60 l/min	Flow Rate: 70 l/min
<b>Steering Hydraulics</b>	Working Pressure: 200 bar	Working Pressure: 200 bar	Working Pressure: 200 bar	Working Pressure: 200 bar
<b>Steering</b>	Fully Hydraulic Articulated Steering	Fully Hydraulic Articulated Steering	Fully Hydraulic Articulated Steering	Fully Hydraulic Articulated Steering
<b>Lifting Capacity</b>	2.000 kg	2.000 kg	2.300 kg	2.300 kg
<b>Tip-over load, straight</b>	1.800 kg	1.800 kg	2.000 kg	2.000 kg
<b>Tip-over load, bent</b>	1.400 kg	1.400 kg	1.500 kg	1.500 kg
<b>Axles</b>	Original SCHÄFFER axles, 6 wheel nut rim; Option: automatic limited slip brake	Original SCHÄFFER axles, 6 wheel nut rim; Option: automatic limited slip brake	Original SCHÄFFER axles, 6 wheel nut rim; planetary axle and automatic limited slip brake as a standard	Original SCHÄFFER axles, 6 wheel nut rim; planetary axle and automatic limited slip brake as a standard
<b>Gross Vehicle Weight</b>	2.700 kg   2.900 kg with cab	2.700 kg   2.900 kg with cab	3.100 kg   3.300 kg with cab	3.100 kg   3.300 kg with cab
<b>Speed</b>	0 – 20 km/h, 2 speeds gear switching under load possible	0 – 20 km/h, 2 speeds gear switching under load possible	0 – 20 km/h, 2 speeds gear switching under load possible	0 – 20 km/h, 2 speeds gear switching under load possible
<b>Electrical System</b>	Operating Voltage 12 V	Operating Voltage 12 V	Operating Voltage 12 V	Operating Voltage 12 V
<b>Fluid Capacities</b>	Fuel: 55 l Hydraulic oil: 50 l	Fuel: 55 l Hydraulic oil: 50 l	Fuel: 85 l Hydraulic oil: 60 l	Fuel: 85 l Hydraulic oil: 60 l

In case of danger from falling objects all loaders have to be equipped with protection roof or cab!



## DIMENSIONS

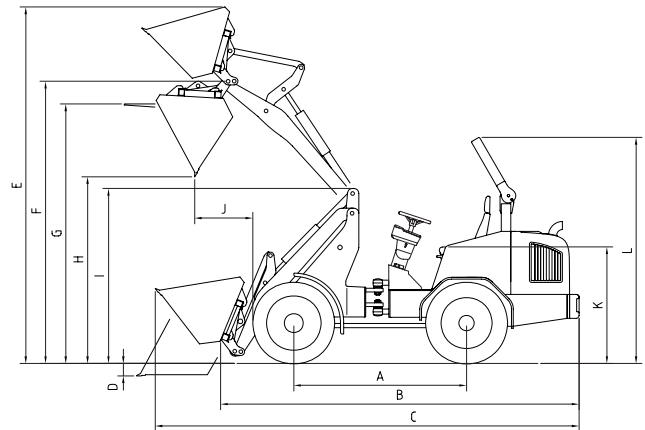
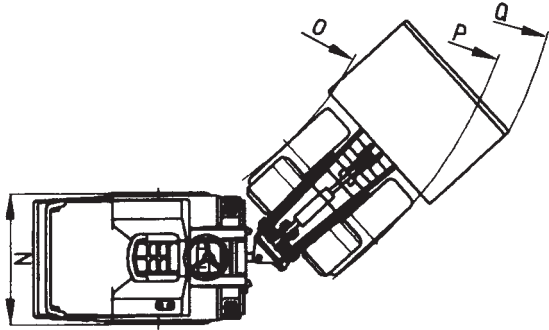

		3350	3360	4350	4360
<b>A</b>	Axle base [mm]	1.730	1.730	1.840	1.840
<b>B</b>	Chassis length [mm]	3.485	3.485	3.680	3.680
<b>C</b>	Total length with standard bucket [mm]	4.185	4.185	4.500	4.500
<b>D</b>	Excavating depth [mm]	90	90	130	130
<b>E</b>	Max. working height [mm]	3.550/3.800*	3.550/3.800*	4.100	4.100
<b>F</b>	Max. bucket pivot point [mm]	2.950/3.200*	2.950/3.200*	3.250	3.250
<b>G</b>	Max. loading height with pallet fork [mm]	2.810/2.940*	2.810/2.940*	3.070	3.070
<b>H</b>	Max. dump height [mm]	2.140/2.390*	2.140/2.390*	2.420	2.420
<b>I</b>	Front end height [mm]	1.700/1.790	1.700/1.790	1.850	1.850
<b>J</b>	Dump range [mm]	560	560	300	300
<b>K</b>	Seat height [mm]	1.150	1.150	1.270	1.270
<b>L</b>	Rollover bar height [mm]	2.360/1.820	2.360/1.820	2.360/1.820	2.360/1.820
	Height with protective roof [mm]	2.240	2.240	2.270	2.270
	Cab height [mm]	2.200	2.200	2.220	2.220
<b>N</b>	Total width [mm]	1.020-1.540	1.020-1.540	1.230-1.600	1.230-1.600
<b>O</b>	Track arc inside [mm]	1.100	1.100	1.310	1.310
<b>P</b>	Track arc outside [mm]	2.120	2.120	2.530	2.530
<b>Q</b>	External radius with standard bucket [mm]	2.500	2.500	2.880	2.880

\* with high lifting reach





The way SCHÄFFER loaders are developed, built and serviced is unique. The difference is our 50 years of experience. First, we think about the operator; we want to make his work safer, more comfortable – and more profitable. To this end, we are equipped with the most modern development and production technologies at our plant in Erwitte, Germany. Ultimately, it is our associates who work with our customers to continuously develop new solutions. Long years of commitment to the company combined with an enduring spirit of innovation are the basis of our exceptional worldwide success.

The name SCHÄFFER Loaders stands for more than one-of-a-kind product quality. It also stands for safety and optimal service, which we guarantee not only in Germany but around the globe.

The purchase of a SCHÄFFER loader is the beginning of a long-term relationship. Only original replacement parts allow your machine to remain a 100% true SCHÄFFER over the years. Only then will it guarantee the reliability you rightly expect. We offer you and our service partners a 24 hour delivery service – 7 days a week, 365 days a year.



*made by SCHÄFFER*

SCHÄFFER offers you a product line-up of over 40 different models, each of which can be adapted to your individual requirements. Our loaders can be used in many different industries: in agriculture or construction, in horticulture or landscaping, in industry and trade, in horse husbandry or warehousing. Whatever the industry, SCHÄFFER is always your first choice.



Your dealer:

# Schaeffer Lader

SCHÄFFER MASCHINENFABRIK GMBH  
Postfach 10 67 | D-59591 Erwitte  
Phone +49 02943 9709-0  
Fax +49 02943 9709-50  
info@schaeffler-lader.de  
www.schaeffler-lader.de